

Candidate surname

Other names

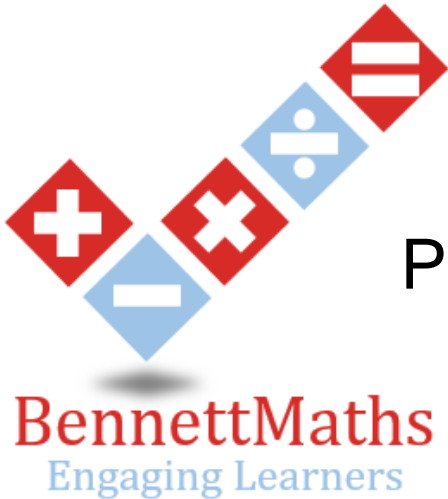

# Practice Paper – Level 2 Certificate

## FURTHER MATHEMATICS

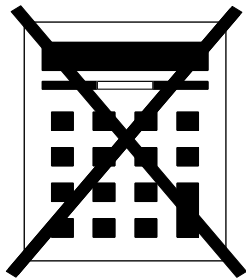

### Materials

For this paper you must have:

- mathematical instruments
- the Formulae Sheet (enclosed).

You must **not** use a calculator.

### Instructions

- Use black ink or black ball-point pen. Draw diagrams in pencil.
- Fill in the boxes at the top of this page.
- Answer **all** questions.
- You must answer the questions in the spaces provided. Do not write outside the box around each page or on blank pages.
- If you need extra space for your answer(s), use the lined pages at the end of this book. Write the question number against your answer(s).
- Do all rough work in this book. Cross through any work you do not want to be marked.
- In all calculations, show clearly how you work out your answer.

### Information

- The marks for questions are shown in brackets.
- The maximum mark for this paper is 80.
- You may ask for more graph paper and tracing paper. These must be tagged securely to this answer book.

Answer **all** questions in the spaces provided.

- 1** Work out the value of  $\sqrt{\frac{t}{40}}$  where  $t = 3.24 \times 10^3$  **[2 marks]**

---

---

---

---

---

Answer \_\_\_\_\_

- 2**  $5n^2 + 2 < 47$   
Work out all the possible **integer** values of  $n$ .

---

---

---

---

---

**[2 marks]**

3 The equations of two straight lines are

$$y + 3x = 4 \quad \text{and} \quad 18y = 6x - 5$$

Show that the lines are perpendicular.

**[2 marks]**

---

---

---

---

---

---

---



$$6 \quad \begin{pmatrix} c & 1 \\ 5d & 3 \end{pmatrix} \begin{pmatrix} -2 & 0 \\ 7 & 3 \end{pmatrix} = \begin{pmatrix} -5 & 3 \\ 0 & 9 \end{pmatrix}$$

Work out the values of  $c$  and  $d$ .

**[3 marks]**

$c =$  \_\_\_\_\_  $d =$  \_\_\_\_\_

**7**  $f(x) = 2x^3 + 13x^2 + 13x - 10$

**[2 marks]**

**(a)** Use factor theorem to show that  $(x + 2)$  is a factor of  $f(x)$

---

---

---

---

**(b)** Hence, or otherwise, fully factorise  $2x^3 + 13x^2 + 13x - 10$

**[3 marks]**

---

---

---

---

---

---

---

---

8

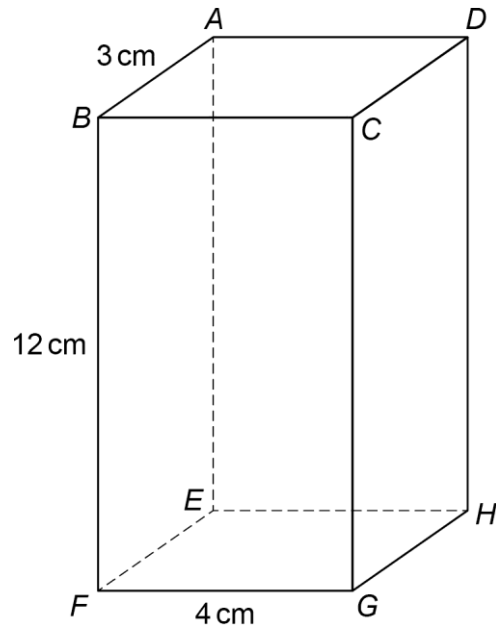
 $ABCDEFGH$  is a cuboid.Work out the length  $FD$ .**[3 marks]**

---

---

---

---

---

---

---

---

---

---

 $FD =$  \_\_\_\_\_  $\text{cm}$

9  $y = \frac{1}{2}x^2 + \frac{3}{4x^4}$

Work out  $\frac{d^2y}{dx^2}$

Give your answer in the form  $a + bx^n$  where  $a$ ,  $b$  and  $n$  are integers.

[3 marks]

---

---

---

---

---

---

---

Answer \_\_\_\_\_

- 10 A set of 4-digit integers each have  
a first digit **greater than 6**  
and  
a second digit **less than 5**

What is the greatest possible number of integers in the set that are multiples of 5?

[3 marks]

---

---

---

---

---

---

---

Answer \_\_\_\_\_

11

A function  $f$  is given by

$$f(x) = -\frac{1}{3}x - 2 \quad 0 \leq x \leq 3$$

$$= x^2 - 4x \quad 3 < x \leq 5$$

$$= 10 - x \quad 5 < x \leq 10$$

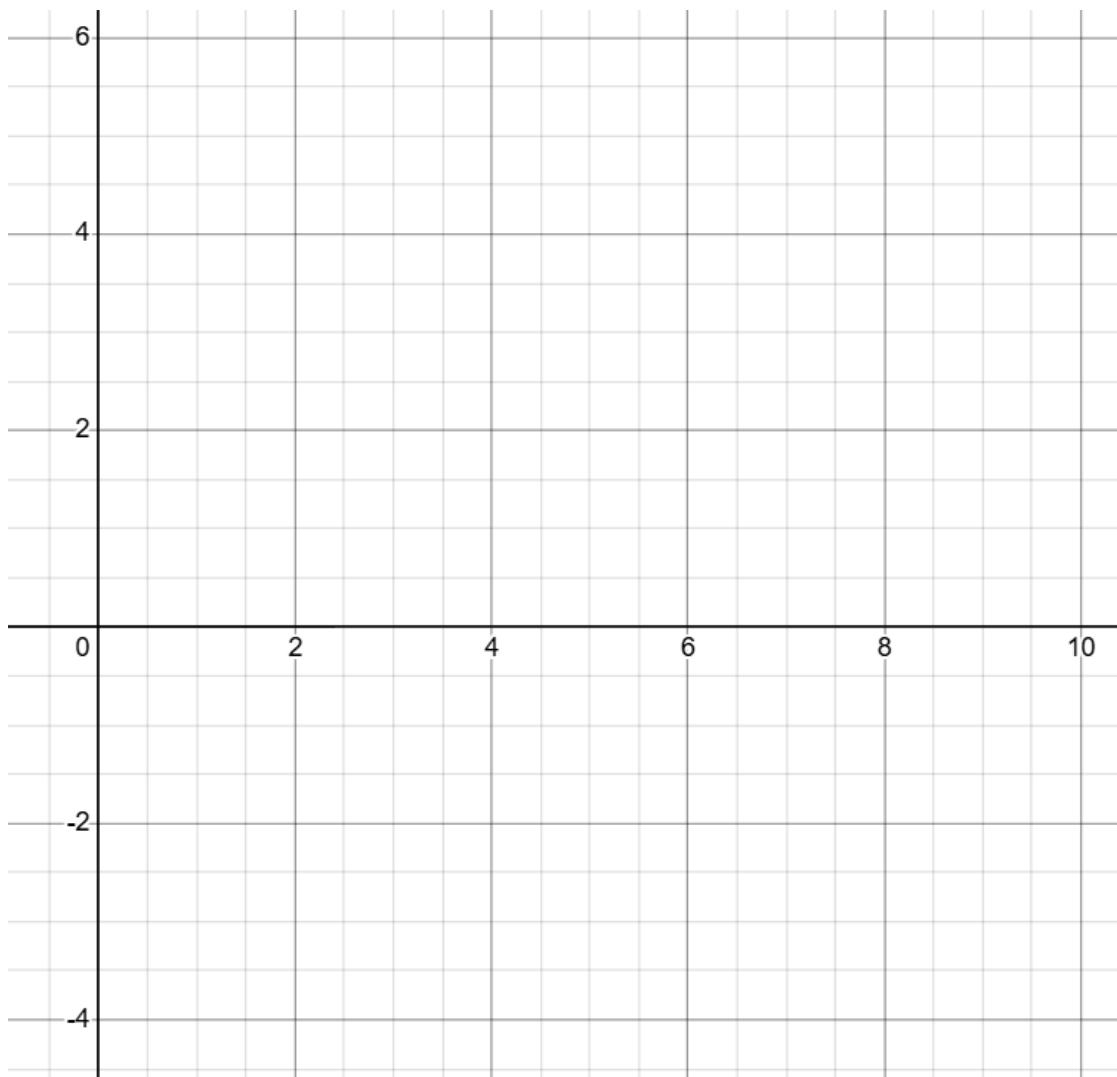
**[4 marks]**Draw a sketch of  $y = f(x)$ 

12

In triangle  $ABC$ ,  $\cos A = \frac{1}{2}$

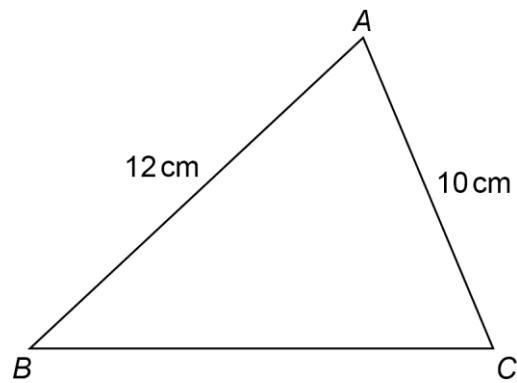

Not drawn  
accurately

Work out the length  $BC$ . Giving your answer in the form  $a\sqrt{31}$

[4 marks]

---

---

---

---

---

---

---

---

---

---

Answer \_\_\_\_\_ cm





**15 (a)** Matrix **H** represents a reflection in the line  $y = -x$

Write down matrix **H**

[1 mark]

$$\mathbf{H} = \begin{pmatrix} \_ & \_ \\ \_ & \_ \end{pmatrix}$$

**15 (b)**  $\mathbf{G} = \begin{pmatrix} 0 & 1 \\ -1 & 0 \end{pmatrix}$

Describe geometrically the single transformation represented by  $\mathbf{G}^2$

[2 marks]

---

---

---

16

$A$ ,  $B$ ,  $C$  and  $D$  are points on a circle, centre  $O$ .  
angle  $OBC$  : angle  $ODC$  = 3 : 1

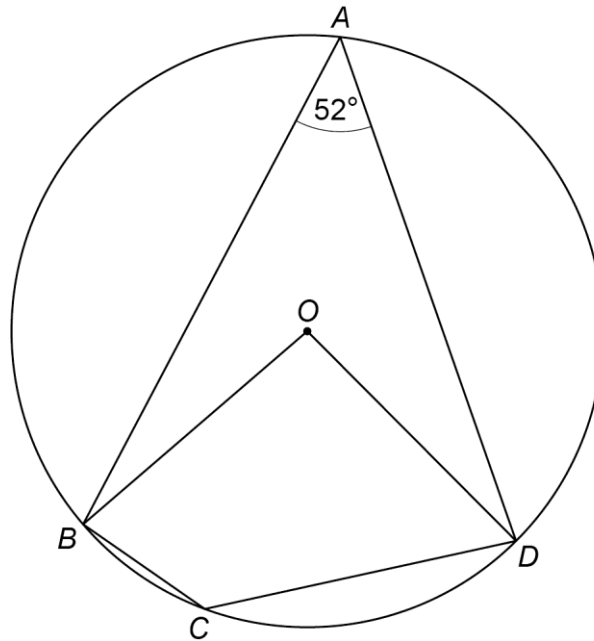
Not drawn  
accurately

Work out the size of angle  $OBC$ .  
You **must** show your working.

[4 marks]

---



---



---



---



---



---



---



---



---



---

Answer \_\_\_\_\_<sup>o</sup>













