

***BennettMaths will be live on TikTok the night before paper 1,
going through all the predicted papers.***

Wednesday 13th May at 8pm

Candidate surname

Other names

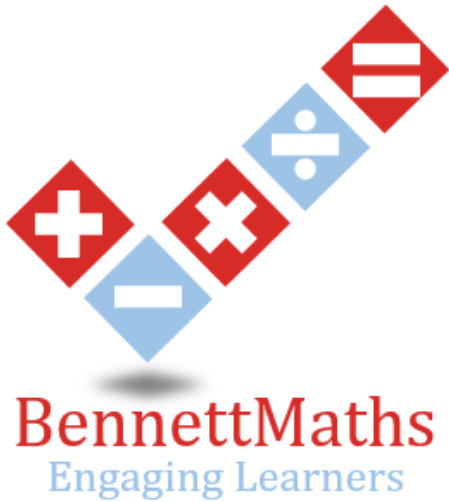

**Pearson
Edexcel**

**Best Guess Paper –
1F
Non-Calculator**

Within this booklet you will find my best guess at which topics might be on the first Edexcel foundation gcse maths paper.

There may be other topics that appear on paper 1, so please ensure that you continue to revise all topics.

The paper consists of 26 questions totalling 80 marks.

1 Round 67.3 to the nearest whole number

.....
(Total for Question 1 is 1 mark)

2 Convert 34% into a decimal

.....
(Total for Question 2 is 1 mark)

3 List the factors of 10

.....
(Total for Question 3 is 1 mark)

4 Simplify $5a + a - 2a$

.....
(Total for Question 4 is 1 mark)

- 5 Sam's dog eats 2 tins of food per day.
Each tin of food costs £2.50.

Work out the total cost to buy a week's worth of dog food.

(Total for Question 5 is 3 marks)

- 6 A movie starts at 2:30pm. It ends 95 minutes later.
Work out the time that the movie ends.

(Total for Question 6 is 2 marks)

- 7 This table shows what 20 students do for lunch.

Sandwiches	School dinner	Go home
7	5	8

Draw a bar chart to show this information.

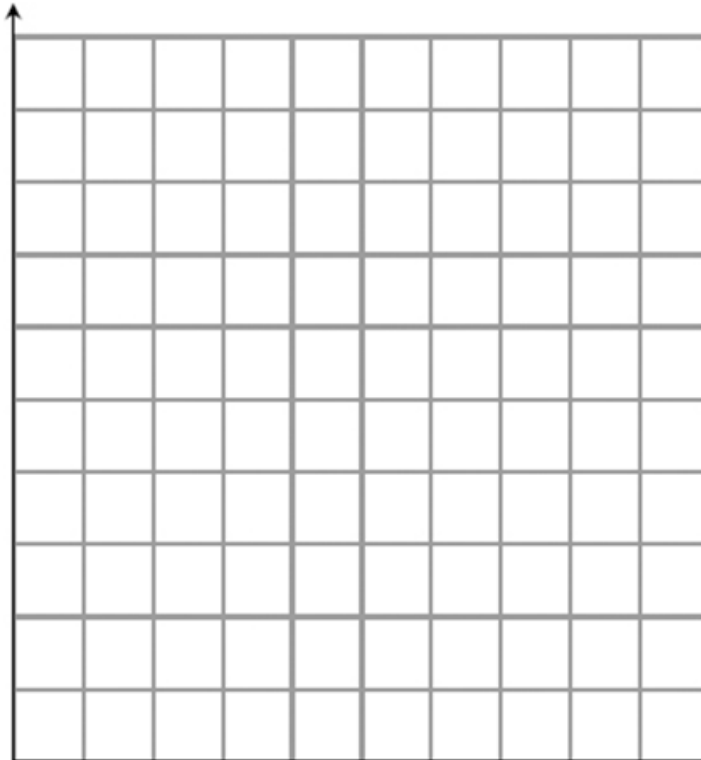

8

10

2

19

Four cards have a number written on them. One of the cards is turned over.
The mean average of the four numbers is 7.5.

Write down the number that is on the final card.

(Total for Question 8 is 3 marks)

9 (a) Expand $3(2x - 4)$

(1)

(b) Factorise fully $12x + 40y$

(1)

(c) Simplify $(a^3)^5$

(1)

(d) Simplify $x^2 \times x^3$

(1)

(e) Solve $5(x + 8) = -11x$

(3)

(Total for Question 9 is 7 marks)

- 10 There are red, blue and green counters in a bag.
The probability of selecting a red or blue counter is shown in the probability table.

Red	Blue	Green
0.4	0.25	

- (a) Complete the probability table to show the probability of selecting a green counter.

.....
(1)

- (b) Write down the fraction of the counters that are Blue.
Give your answer in its simplest form.

.....
(2)

(Total for Question 10 is 3 marks)

-
- 11 Work out 30% of 186

.....
(Total for Question 11 is 2 marks)

- 12 ABC is a right-angled triangle.
 $AB = 2x + 4$ cm
 $BC = 5x$ cm

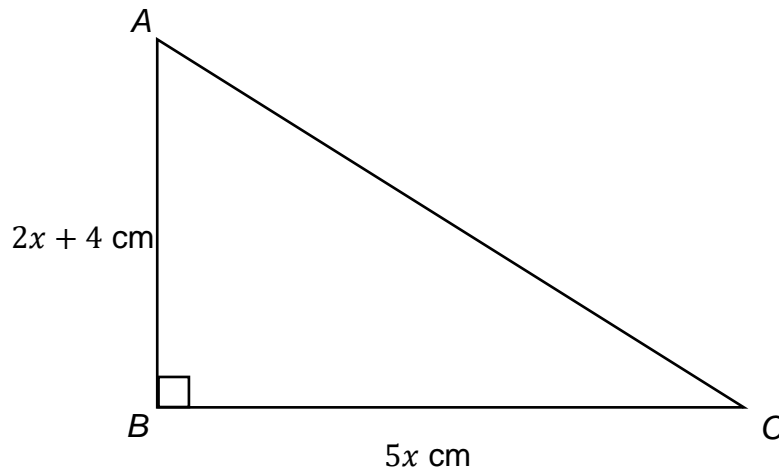

- (a) Work out the area of the triangle.
Giving your answer in the form $ax^2 + bx$ cm². Where a and b are integers

(3)

- (b) The area of another shape is $4x^2 + 6x$.
If the value of x is 3.
Work out the value of the area of this shape.

(2)

(Total for Question 12 is 5 marks)

13 Convert 12mm^2 into cm^2

(Total for Question 13 is 2 marks)

14 Leo and Margot share some money in the ratio 7:2.
Leo receives £35 more than Margot.

Work out how much money Margot receives

(Total for Question 14 is 3 marks)

- 15 The frequency table below shows the pocket money received by 20 pupils.

Pocket Money	Frequency
$0 \leq x < 4$	6
$4 \leq x < 6$	8
$6 \leq x < 8$	2
$8 \leq x < 10$	4

Work out an estimate for the mean amount of pocket money received by each pupil.

.....
(Total for Question 15 is 3 marks)

- 16 It takes 5 workers 6 days to complete a project.

Assuming all workers complete the work at the same rate.

Work out how long it would take 2 workers to complete the project.

.....
(Total for Question 16 is 2 marks)

17

(a) Express 98 as a product of primes

(2)

(b) Hence, or otherwise, find the highest common factor (HCF) of 98 and 56

(2)

(Total for Question 17 is 4 marks)

18 Work out the value of

$$\frac{2^8 \times 2^{-4}}{2^{-2}}$$

(Total for Question 18 is 3 marks)

19

Triangle ABC is shown below.

AB = 4cm

AC = 8cm

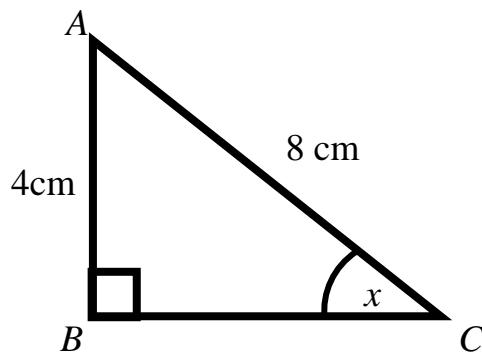

Work out the size of angle x

(Total for Question 19 is 3 marks)

20

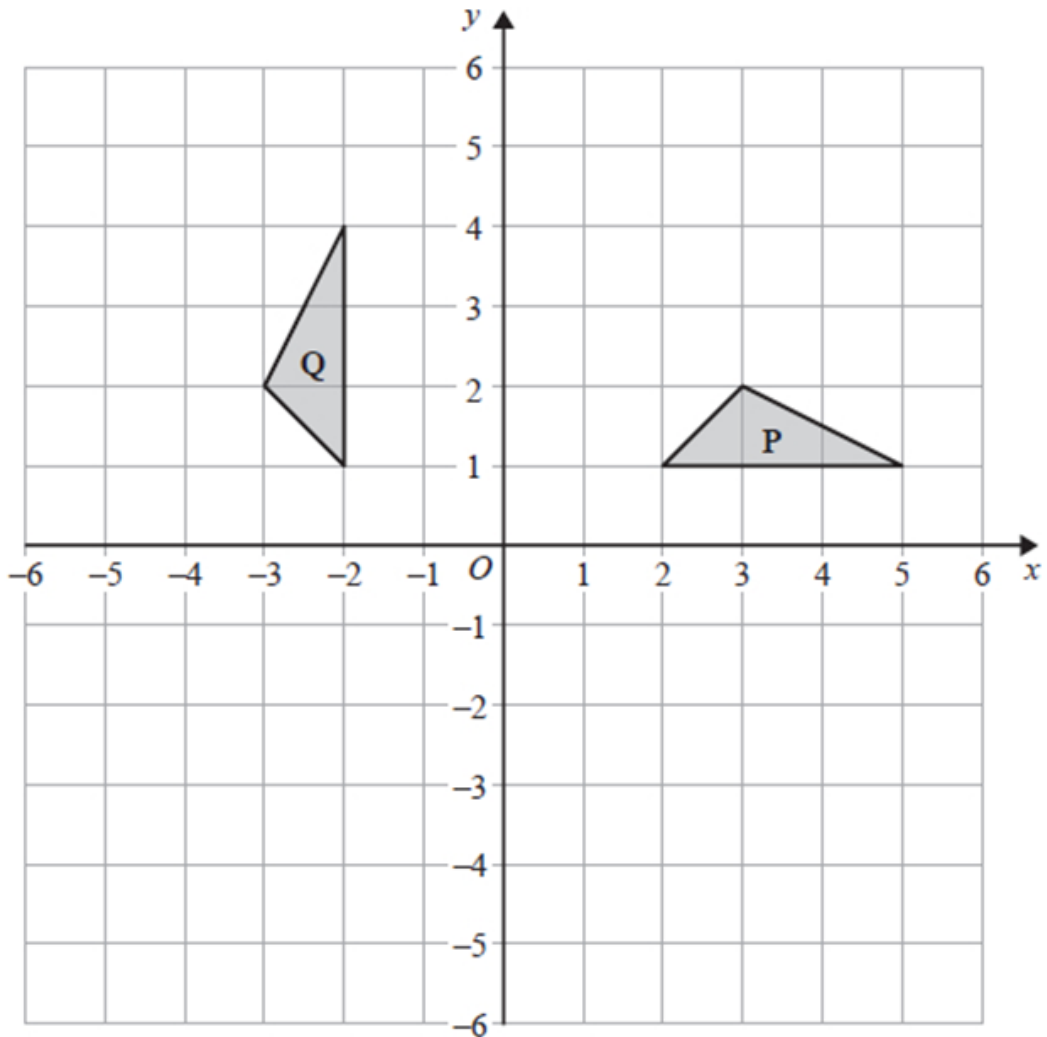

Describe the single transformation that maps triangle P onto triangle Q

(Total for Question 20 is 2 marks)

21 Below is a cuboid

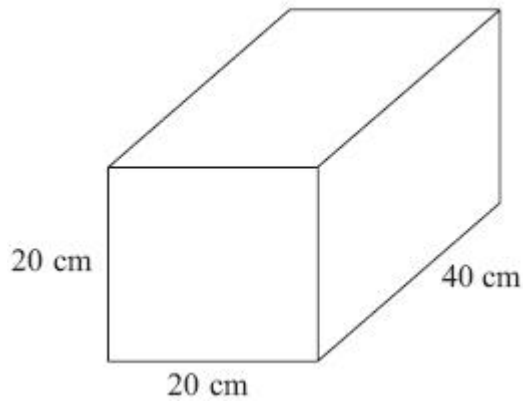

Work out the volume of the shape above stating your units.

22 ABCD is a rectangle.

$$3\frac{3}{4} \text{ cm}$$

$$1\frac{3}{8} \text{ cm}$$



(a) Work out the perimeter of ABCD

(3)

(b) Work out the area of ABCD

(2)

(Total for Question 22 is 5 marks)

23 Margot takes part in a 5 km fun run.

During the first 3 km she runs at an average speed of 6 km/h.

She is aiming to complete the race in under 54 minutes.

Work out the average speed that she needs to maintain to finish in under 54 minutes.



***BennettMaths will be live on TikTok the night before paper 1,
going through all the predicted papers.***

Wednesday 13th May at 8pm

24 Solve

$$3x - 4 = 5x + 7$$

(Total for Question 24 is 3 marks)

25(a) Convert 3.45×10^4 into an ordinary number

.....
(1)

(b) Convert 0.00672 into standard form

.....
(1)

(c) Work out the value of

$$\frac{(1 \times 10^4) \times (6 \times 10^3)}{(2 \times 10^2)}$$

Giving your answer in standard form

.....
(2)

(Total for Question 25 is 4 marks)

26(a) Complete the table for $y = x^2 - 2x - 3$, for all values of x between -2 and 4

x	-2	-1	0	1	2	3	4
y							

(2)

(b) Draw the graph of $y = x^2 - 2x - 3$, for all values of x between -2 and 4

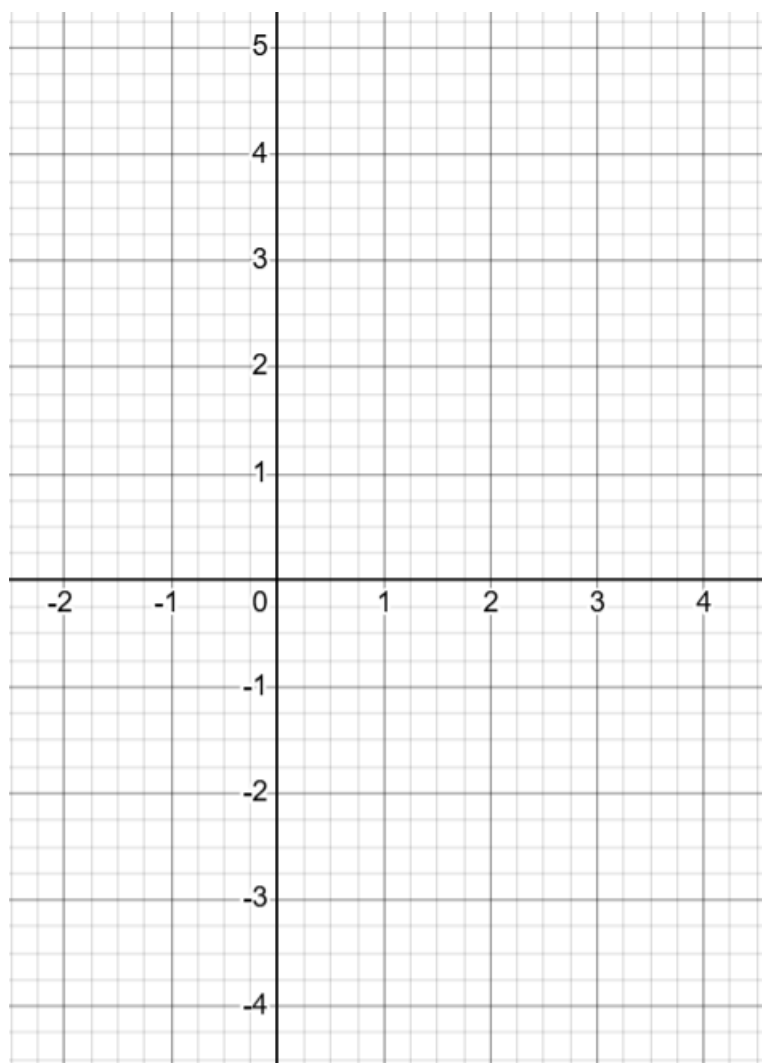

(2)

(c) Find estimates of the roots of $-2 = x^2 - 2x - 3$

(2)

(Total for Question 26 is 6 marks)